



# BELCO MOWER SERIES

## LCM180 - 1.8T ATM Mower Trailer

### Description

The Belco LCM180 is a single-axle 1.8T mower trailer purpose-built for serious operators. Engineered to deliver reliable daily transport for ride-on mowers and associated equipment, the trailer features a manual tilt deck for ramp-free loading, a mesh floor for grip and debris fall-through, and a hot dip galvanised finish for long-term corrosion resistance. With Cruisemaster RMX suspension and a balanced single-axle layout, the LCM180 is straightforward to tow, easy to manoeuvre on tight sites, and built to keep maintenance and downtime low.

### Key Features

- Manual tilt deck with over-centre locking — fast, ramp-free loading
- Mesh floor for grip underfoot and clean debris fall-through
- Split beavertail rear for smooth, low-angle loading
- Cruisemaster RMX suspension for ride quality and long-haul comfort
- Single-axle layout — easy to manoeuvre on tight sites and suburban driveways
- Hot dip galvanised finish for low-maintenance corrosion protection
- 10" Electric brakes
- ADR compliant for Australian road use
- LED lighting and high-visibility marker lights

*\* Pictures shown may include Upgrade Packages*

PHONE: 07 3490 4500 EMAIL: SALES@BELCOCUSTOMTRAILERS.COM.AU

**WWW.BELCOCUSTOMTRAILERS.COM.AU**



## Safety Features

The manual tilt system features secure over-centre locking to prevent unwanted movement during transport, with 10" electric brakes delivering controlled, responsive stopping performance under load.

ADR-compliant LED lighting and high-visibility markers ensure on-road visibility, and the balanced single-axle design supports consistent load distribution for stable, predictable towing.



## Operational Benefits

Ramp-free tilt loading reduces setup time and manual handling, while the mesh floor sheds dirt and debris during transport to keep the deck clean. Cruisemaster RMX suspension delivers smooth towing, and 10" electric brakes provide proportional, controller-modulated stopping with less maintenance than hydraulic override systems. Less time setting up, less time servicing, more time on the job.



## Design Considerations

The LCM180 is built for daily commercial mower applications, with a layout that balances strength, usability, and payload within the 1.8T ATM rating. The single-axle configuration has been specified for manoeuvrability where it matters — residential driveways, narrow access points, and council reserves — making the trailer well-suited to owner-operated landscaping and grounds maintenance work.



*\* Pictures shown may include Upgrade Packages*



## Specifications - 1.8T ATM Single Axle Light Commercial Mower Trailer

DIMENSIONS		CAPACITY		CONSTRUCTION	
Design Standard	AS3990	Maximum Payload	*1,100	Chassis	100x50x3mm RHS
Weld Standard	AS1554-Part 1 (GP)	ATM	1,800 KG	Drawbar	100x50x3mm RHS
Deck Length	~2,400 MM	GTM	~1,725 KG	Cross Members	50x50x2.5mm RHS
Deck Width	~2,000 MM	Tyre Size	195/14	Sides	N/A
Weight (Tare)	~700 KG	Tyre Pressures	450 kPa	Ramps	Split Beaver Tail
		Brakes	10" Parallel Electric Brakes	Floor	FM14 Mesh
			<small>*impacted by options taken that change TARE weight</small>	Rear Legs	N/A

RUNNING GEAR		GENERAL		OPERATIONAL	
Suspension	Cruisemaster RMX	Lighting	Multi Volt LED/Marker Lights	Upgrades Available for attachment Racking	
Axles	50mm Square Parallel Drop Axle	Coupling	50mm Ball Electric Hitch		
Springs	2.3T - 7 Leaf	Safety Chains	10mm Rated on Belco Berg lock		
Rims	14" Polished Alloy	Trailer Plug	7 Pin Flat		
Tyres	195/14 Light Truck	Spare Wheel	Included		
Wheel Nut Indicators	Optional Upgrade	Mudguards	2.1mm Checker Plate		
		Wheel Chocks	Optional Upgrade		
		Handbrake	Mechanical Override		
		Break Away	N/A		
		Jockey Wheel	8' Swing Away		

## WARRANTY

**7 Year Structural** – Comprehensive coverage on the chassis and drawbar for total peace of mind.

**2 Year Body** – Coverage for Belco-manufactured body components like ramps, gates, walls, and frames.

**1 Year 3rd Party Components** – Manufacturers warranty, with Belco's support through the claim process.

**Return-to-Base Support** – Fast, efficient warranty service at Belco's Brisbane facility.

**Designed for Work** – Warranty applies equally to private and commercial use.

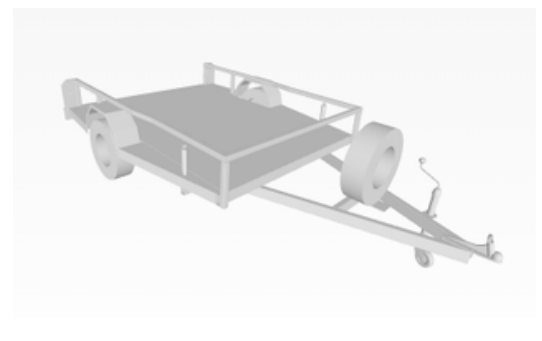

\* Pictures shown may include Upgrade Packages

