



BELCO MOWER SERIES

MCM200 - 2T ATM Mower Trailer

Description

This Belco mower trailer is purpose-built for durability, practicality, and everyday commercial use. The trailer is fitted with high sides and a split rear gate for easy loading and unloading, while the drawbar has been configured with an open mower deck —providing quick access, improved visibility, and greater versatility compared to a traditional enclosed box. With ample storage, a stable tandem axle setup, and a layout designed for efficiency on the job, this trailer is ideal for operators needing a tough, functional solution for transporting equipment safely and efficiently.

Key Features

- 10x6 Tandem Axle Trailer
- Purpose-built 2 Shelf storage box for secure transport of:
 - Fuel, Oils & Lubricants
 - Small Tools and Accessories
- 400mm high trailer sides fitted with a 600mm high cage
- Open Mower Deck to house a single push mower mounted on the Drawbar
- Whipper Box to house 2 x Whipper Snippers & Pole Saw
- No Electric Brake Controller Required
- Gas Strut Assisted Mesh Bi Fold Full Width Ramp

** Pictures shown may include Upgrade Packages*



Safety Features

This trailer is built with safety front of mind, featuring a fully galvanised chassis for structural integrity and longevity, a stable tandem axle setup for improved load distribution and towing control, and a secure coupling with safety chains. The inclusion of mechanical braking provides reliable stopping performance without the need for an in-cab brake controller, reducing setup complexity while maintaining safety.



Operational Benefits

Designed for efficiency on the job, this trailer offers easy loading with a split rear gate and practical high sides for securing various loads. The open front platform provides quick, convenient access to mowers without the restriction of an enclosed box, saving time on-site. Mechanical brakes eliminate the requirement for a brake controller, allowing the trailer to be towed by a wider range of vehicles with minimal setup.



Design Considerations

The trailer has been designed to balance strength, usability, and flexibility, with a fully galvanised finish to minimise maintenance and maximise lifespan. The shift from an enclosed mower box to an open platform improves accessibility and versatility while reducing weight. The overall layout supports efficient load management—ensuring equipment can be transported securely while remaining easy to access and operate in day-to-day applications.



** Pictures shown may include Upgrade Packages*



Specifications - 2T ATM Tandem Axle Medium Commercial Mower Trailer

DIMENSIONS

Design Standard	AS3990
Weld Standard	AS1554-Part 1 (SP)
Deck Length	~3,000 MM
Deck Width	~1,800 MM
Weight (Tare)	~1,200 KG

CAPACITY

Maximum Payload	*800 KG
ATM	2,000 KG
GTM	~1,800 KG
Tyre Size	185/14
Tyre Pressures	450 kPa
Brakes	10" Slimline Mechanical Brakes

*impacted by options taken that change TARE weight

CONSTRUCTION

Chassis	100x50x3mm RHS
Drawbar	100x50x3mm RHS
Cross Members	50x50x2.5mm RHS
Sides	400mm high
Ramps	Alloy Mesh - Gas Strut Assisted
Floor	2.1mm Steel Checker Plate
Rear Legs	N/A

RUNNING GEAR

Suspension	Rock Roller Load Share
Axle/Stub	50mm Sq Slimline Bearing (3T)
Springs	3T - 7 Leaf
Rims	14" White Steel Ford
Tyres	185/14 Light Truck
Wheel Nut Indicators	Optional Upgrade

GENERAL

Lighting	Multi Volt LED/Marker Lights
Coupling	50mm Ball Mechanical Hitch
Safety Chains	10mm Rated on Belco Berg Lock
Trailer Plug	7 Pin Flat
Spare Wheel	Included
Mudguards	2.1mm Checker Plate
Wheel Chocks	Optional Upgrade
Handbrake	Mechanical Override
Break Away	N/A
Jockey Wheel	8' Swing Away

OPERATIONAL

Attachment Racking	Whipper Box to house 3 units
	Single Open Mower Deck on Drawbar
	600mm High Cage
	2000x300x600 Storage Box
Tie Downs	Tie Rail

WARRANTY

7 Year Structural – Comprehensive coverage on the chassis and drawbar for total peace of mind.

2 Year Body – Coverage for Belco-manufactured body components like ramps, gates, walls, and frames.

1 Year 3rd Party Components – Manufacturers warranty, with Belco's support through the claim process.

Return-to-Base Support – Fast, efficient warranty service at Belco's Brisbane facility.

Designed for Work – Warranty applies equally to private and commercial use.

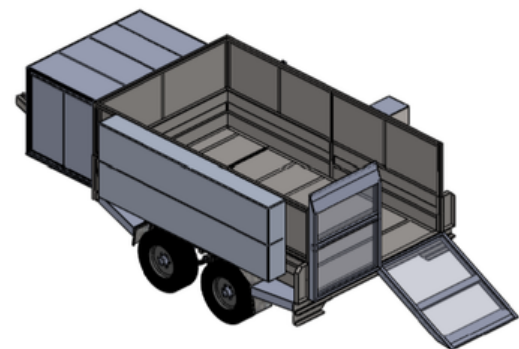

* Pictures shown may include Upgrade Packages

